

MiniRail Base Set

TECHNICAL SHEET

Item Number	Descripción	Part Number
1	MiniRail XPRess Base 17in w/EPDM, Mill	4000073 MiniRail Base Set
2	MiniRL Screw w/EPDM JF3, 29g, 25mm	

MINIRAIL BASE



Propiedades mecánicas

	MiniRail Base
Material	Aluminio Serie 6000
Resistencia a la tracción	37.7 ksi [260 MPa]
Fuerza de rendimiento	34.8 ksi [240 MPa]
Peso	0.84 lbs/pc [0.378 kg/pc]
Terminado	Aluminio

Propiedades seccionales

	MiniRail Base
Sx	0.183 in ³ [2.9988 cm ³]
Sy	0.176 in ³ [2.8841 cm ³]
A [X-Section]	0.507in ² [3.2709 cm ²]

Unidad de medida: [mm] pulgadas

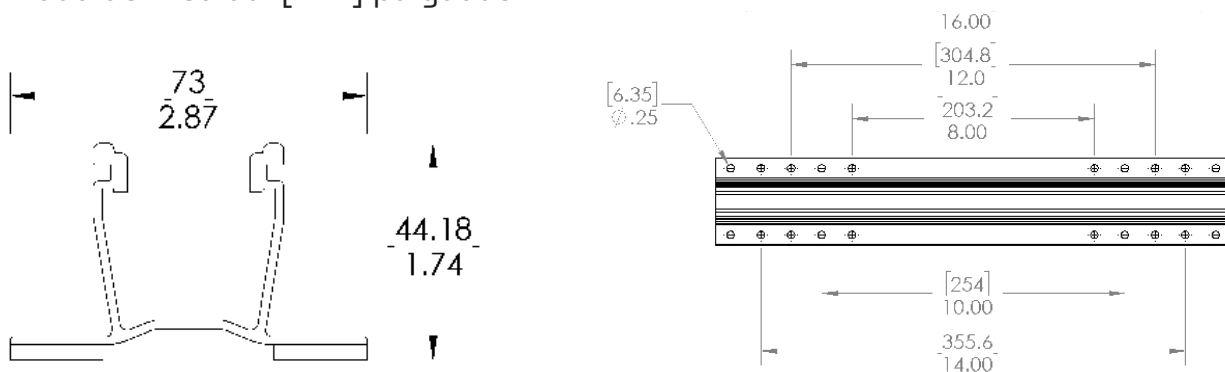

Notas:

- ▶ Valores estructurales y diagramas de span son determinados de acuerdo con el Manual de diseño de aluminio y ASCE 7-16.
- ▶ Certificación UL2703.