

# K2 Armor w/ Big Foot

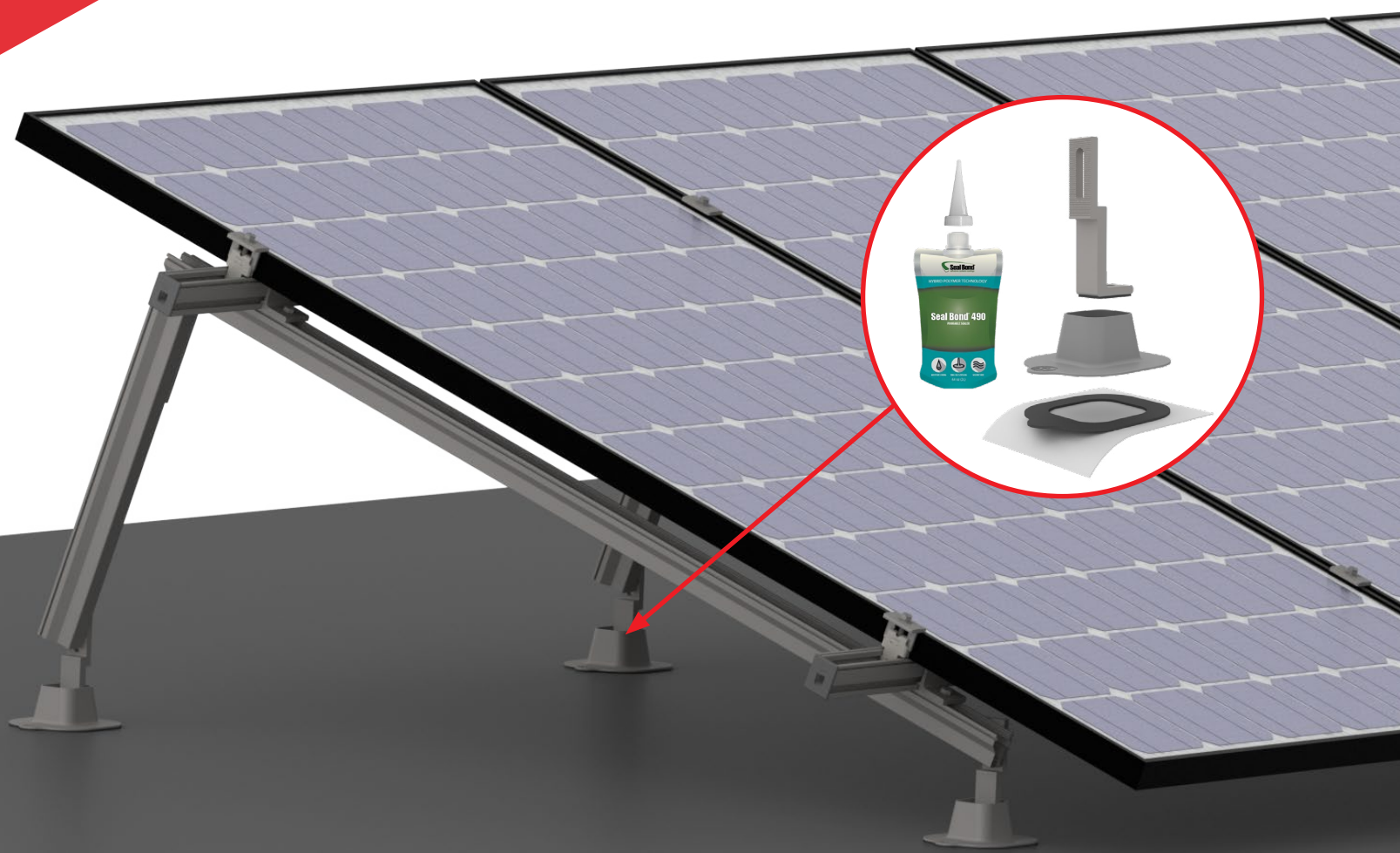

DATA SHEET



Item Number	Description	Part Number
1	K2 Armor w/Big Foot, Kit	4000559



# PRODUCT FEATURES



- / High quality, German-engineered roof attachment optimized for flat roof installations
- / Redundant waterproofing with K2 EverSeal preassembled on Big Foot and Armor
- / K2 Armor is smaller than most curbs on the market at 2"
- / One pouch of Seal Bond 490 liquid (2L) will fill 10 K2 Armors
- / 100% code compliant, structural validation for all solar states
- / Minimize pallet and freight costs

# TECHNICAL DATA

	K2 Armor w/Big Foot, Kit
Part Number(s)	4000559
Roof Type	TPO, rolled asphalt, concrete and EPDM membrane
Material	Armor: PA 6.6 GF35 UV Resistant Big Foot: Aluminum
Roof Connection	Armor: K2 EverSeal and Seal Bond 490 Big Foot: 5/16" Lag screw
Certifications	TAS 100 and Wind Driven Rain Test
Weight (Piece)	Armor: 85.85 g Big Foot: 1748.2 g Seal Bond 490: 3210 g
Weight (Box)	13.52 lbs
Box Quantity	10 K2 Armors 2" 10 Big Foot 1 SealBond Pouch w/nozzle

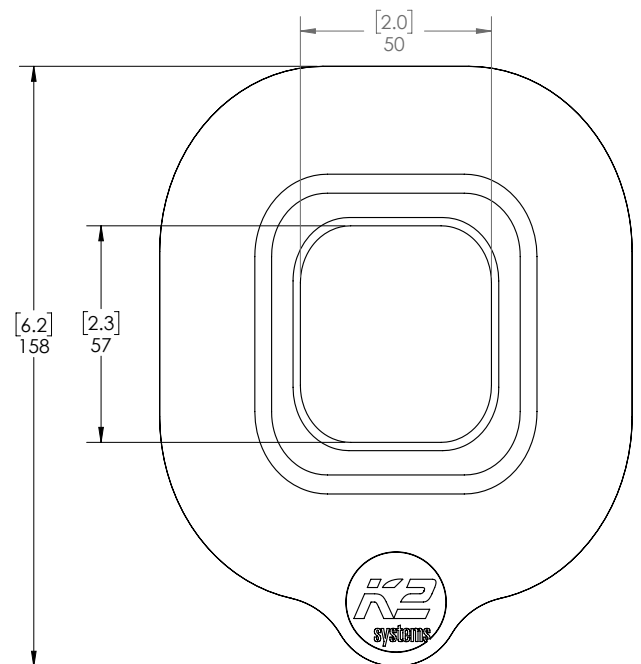
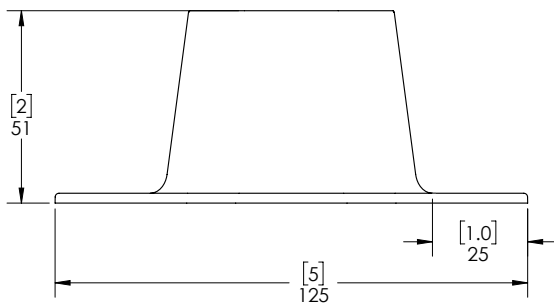
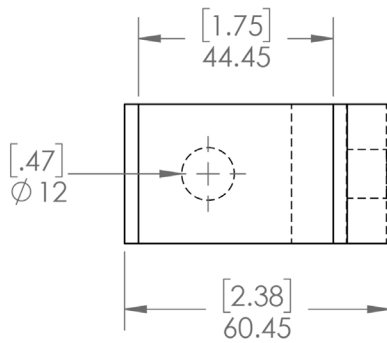
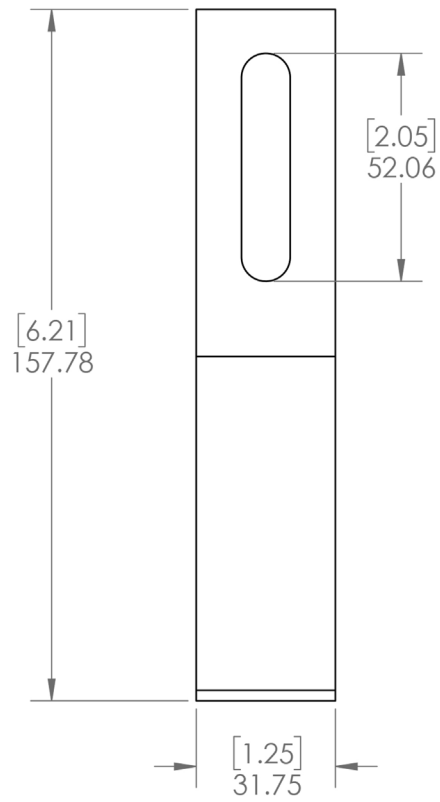
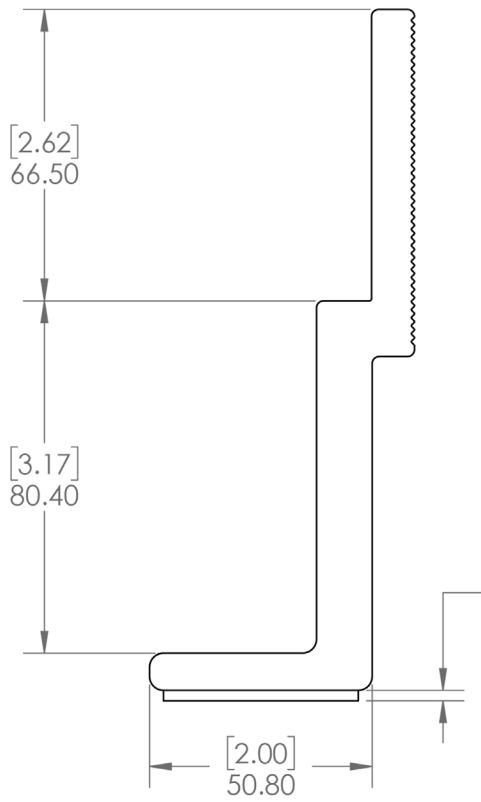



# Connecting Strength

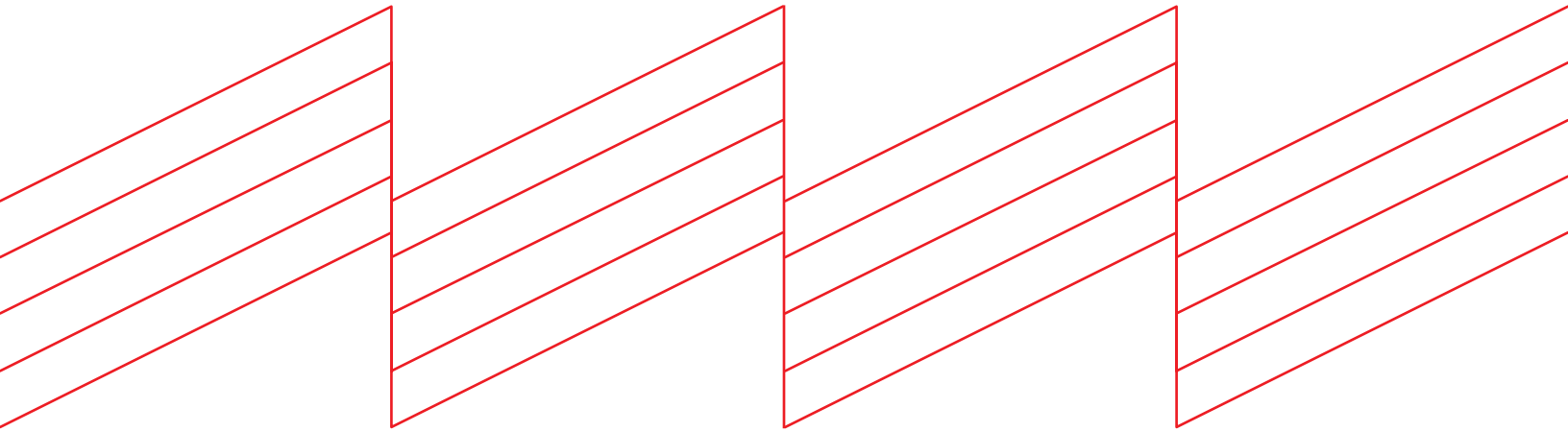

## **K2 Systems, LLC**

4665 North Ave. Suite I • Oceanside, CA 92056 •  
USA +1.760.301.5300 • [infous@k2-systems.com](mailto:infous@k2-systems.com)  
[www.k2-systems.com/en-us](http://www.k2-systems.com/en-us)

## **Everest Solar Systems S de RL de CV**

Calle Coral 2628 Int. 1 • Col. Residencial  
Victoria, CP 44560 • Guadalajara, Jal. • México  
+52.33.3575.9380 • [info@k2-systems.mx](mailto:info@k2-systems.mx)  
[www.k2-systems.com/es-mx](http://www.k2-systems.com/es-mx)