

Rail Connector

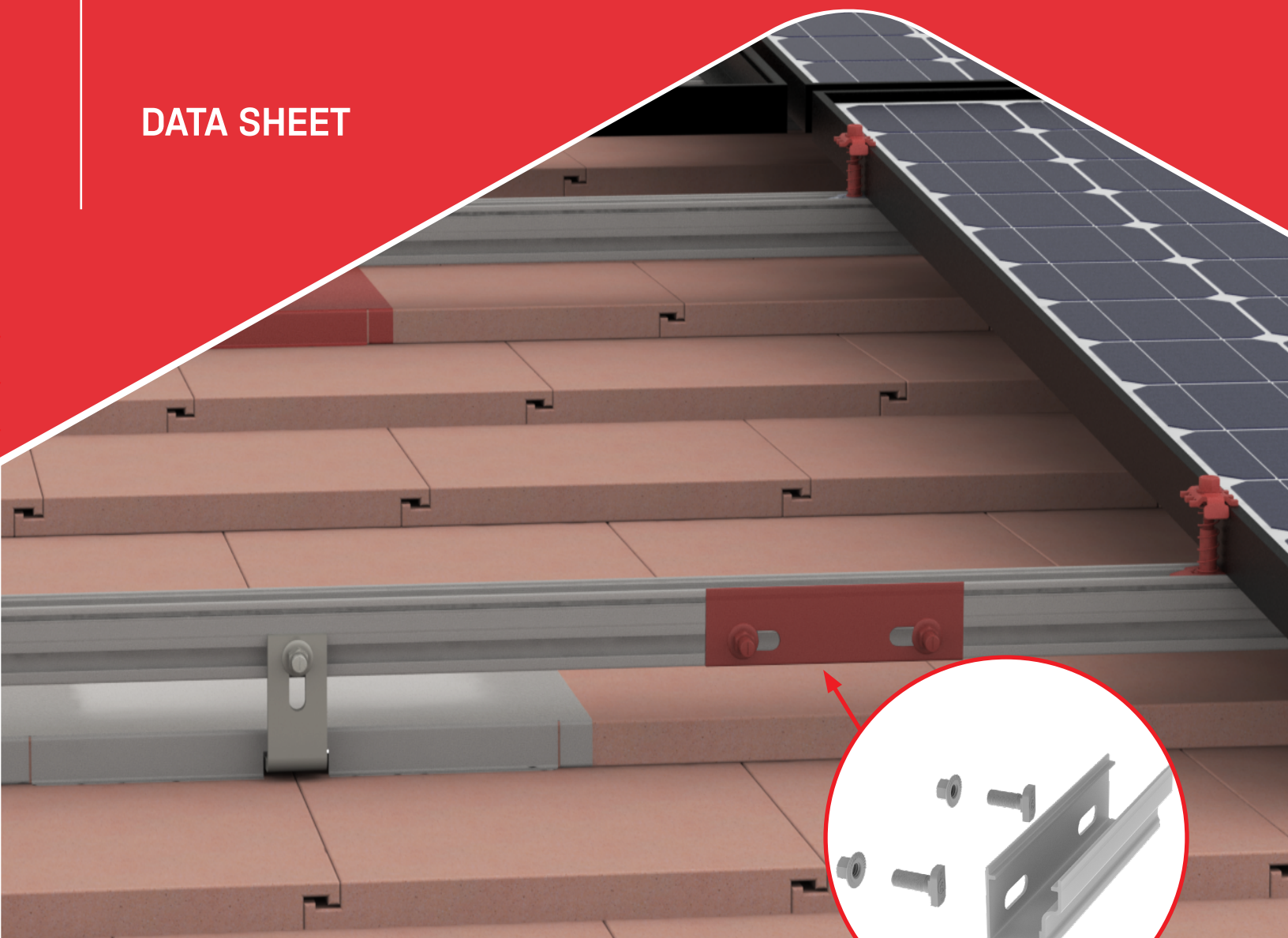

DATA SHEET



PRODUCT FEATURES

- / Conecta dos rieles, haciéndolo como un riel sólido
- / Disponible para todos los perfiles CrossRail
- / Material de aluminio con accesorios de acero inoxidable
- / Certificación UL 2703

INFORMACIÓN TÉCNICA



	Rail Connector CR 44-X, Set
Material	Aluminio grado marino
Terminado	Aluminio
Compatibilidad	CrossRail 44-X
Connector Structural	Si
Cantidad/Caja	20
Garantía	25 Años
Florida Product Approval	FL#46869

Units: [mm]

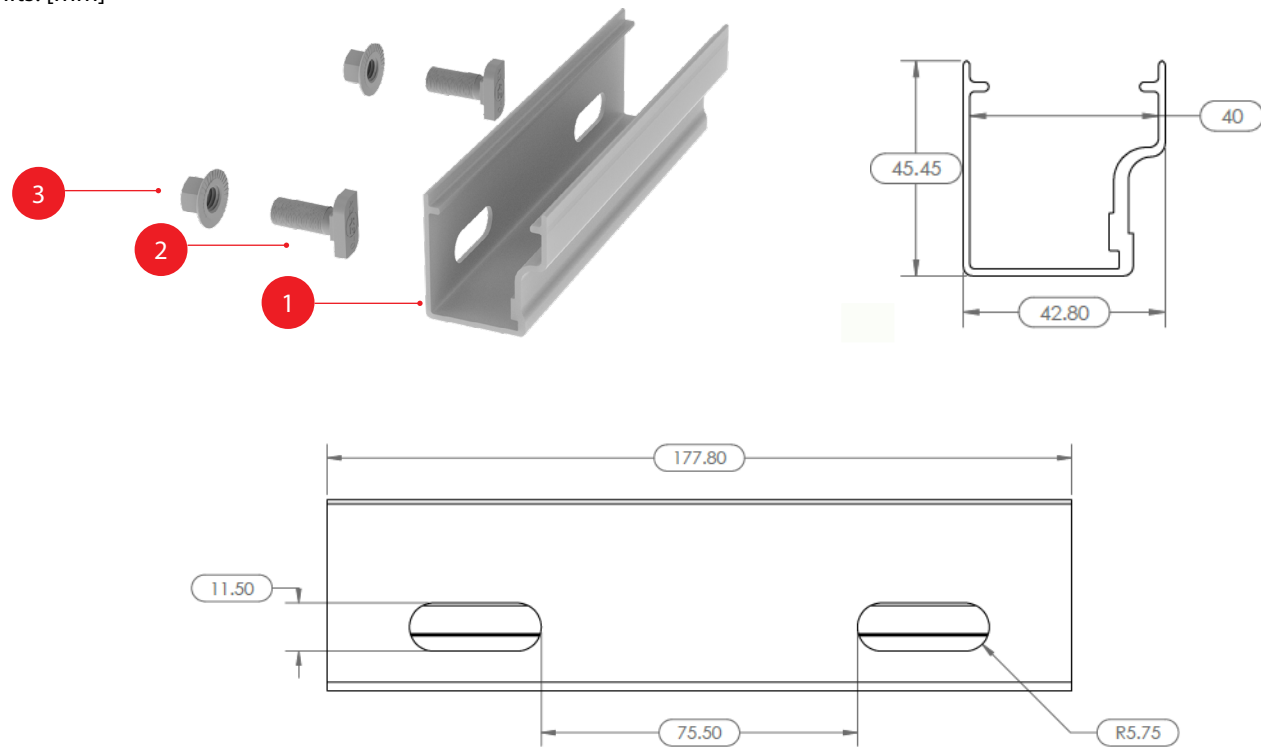

Item Number	Descripción	Part Number
1	Rail Connector CR 44-X, Mill / Dark	4000051 Rail Connector CR 44-X, Set, Mill 4000052 Rail Connector CR 44-X, Set, Dark
2	T-Bolt 28/15 M10×20 SS, CR48/80	
3	Hex Flange Nut Serr, SS, M10, 1/2" Socket	

INFORMACIÓN TÉCNICA



	Rail Connector CR 48-X y 48-XL, Set
Material	Aluminio grado marino
Terminado	Aluminio
Compatibilidad	CrossRail 48-X y 48-XL
Connector Structural	Si
Cantidad/Caja	10
Garantía	25 Años
Florida Product Approval	FL#46869

Units: [mm]

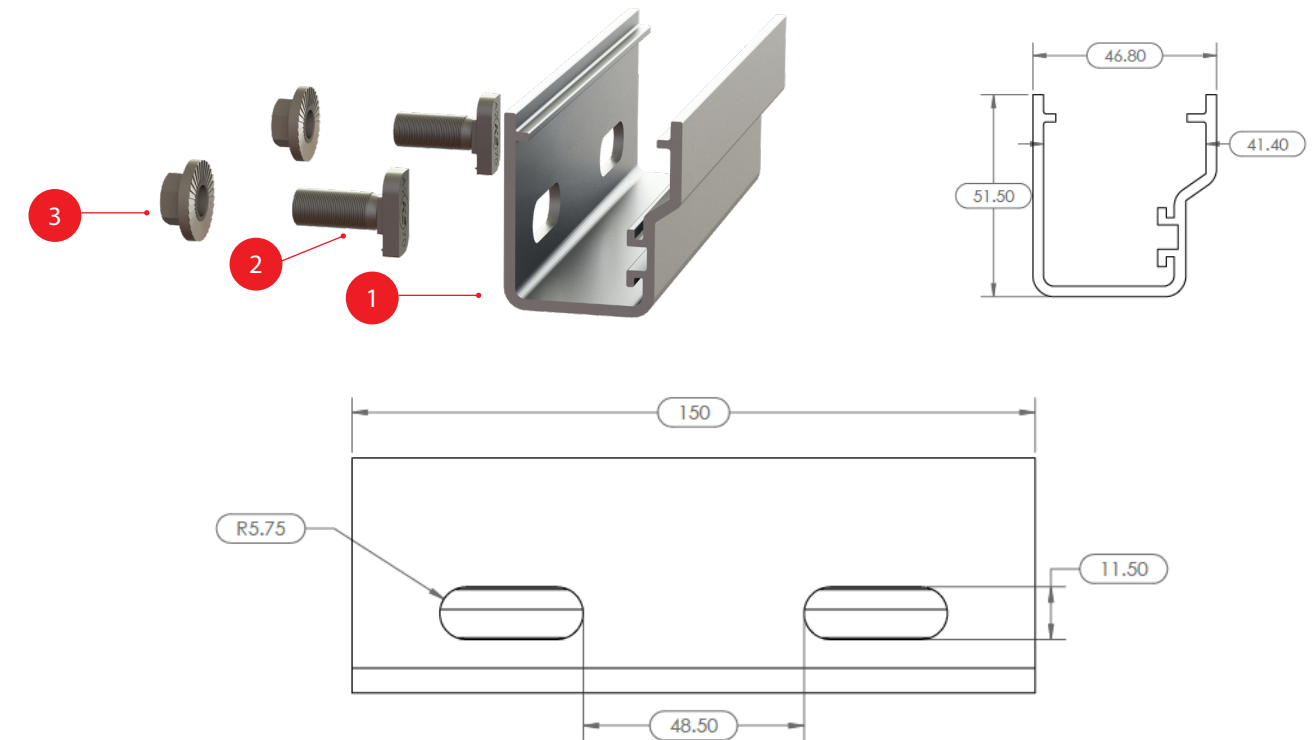

Item Number	Descripción	Part Number
1	Rail Connector CR 48-X, XL Struc, Mill/Dark	4000385 RailConn CR 48-X,48-XL Struct Set, Mill 4000386 RailConn CR 48-X,48-XL Struct Set, Dark
2	T-Bolt 28/15 M10×20 SS, CR48/80	
3	Hex Flange Nut Serr, SS, M10, 1/2" Socket	

INFORMACIÓN TÉCNICA



	Rail Connector CR 80 Set
Material	Aluminio grado marino
Terminado	Aluminio
Compatibilidad	CrossRail 80
Conector Structural	No
Cantidad/Caja	10
Garantía	25 Años
Florida Product Approval	FL#46869

Units: [mm]

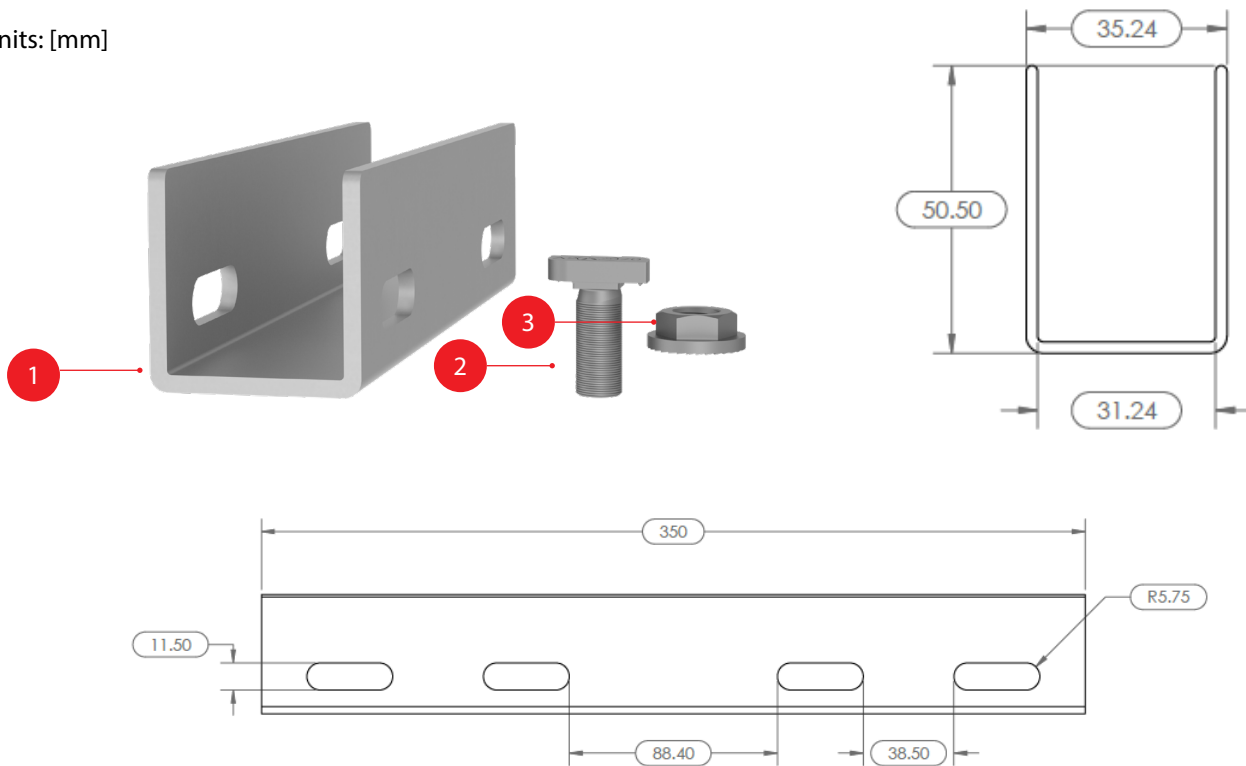

Item Number	Descripción	Part Number
1	Rail Connector CR80, Mill	4001196 RailConn UL 2703 Set, CR80, Mill
2	T-Bolt 28/15 M10×25 SS, CR48/80	
3	Hex Flange Nut Serr, SS, M10, 1/2"Socket	



Connecting Strength

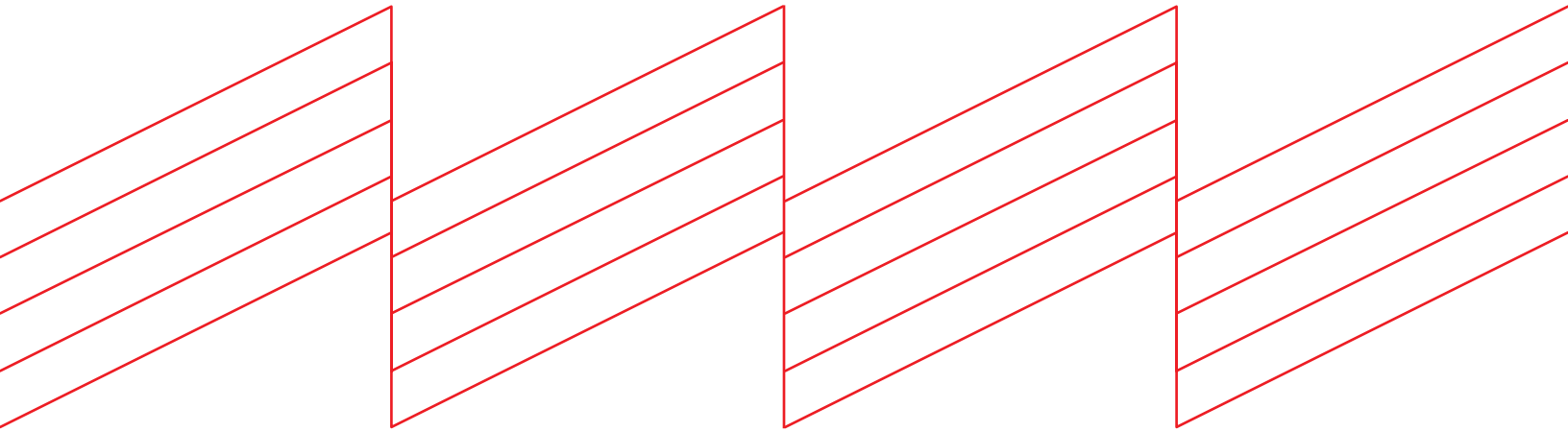

K2 Systems
Calle Coral #2628 interior 1
Col. Residencial Victoria, C.P. 44560, Guadalajara, Jal.
México
+521 (33) 35 75 93 80
info@k2-systems.com
www.k2-systems.com