



Connecting Strength

Tool-less Rail Connector

44-X



QUICK GUIDE

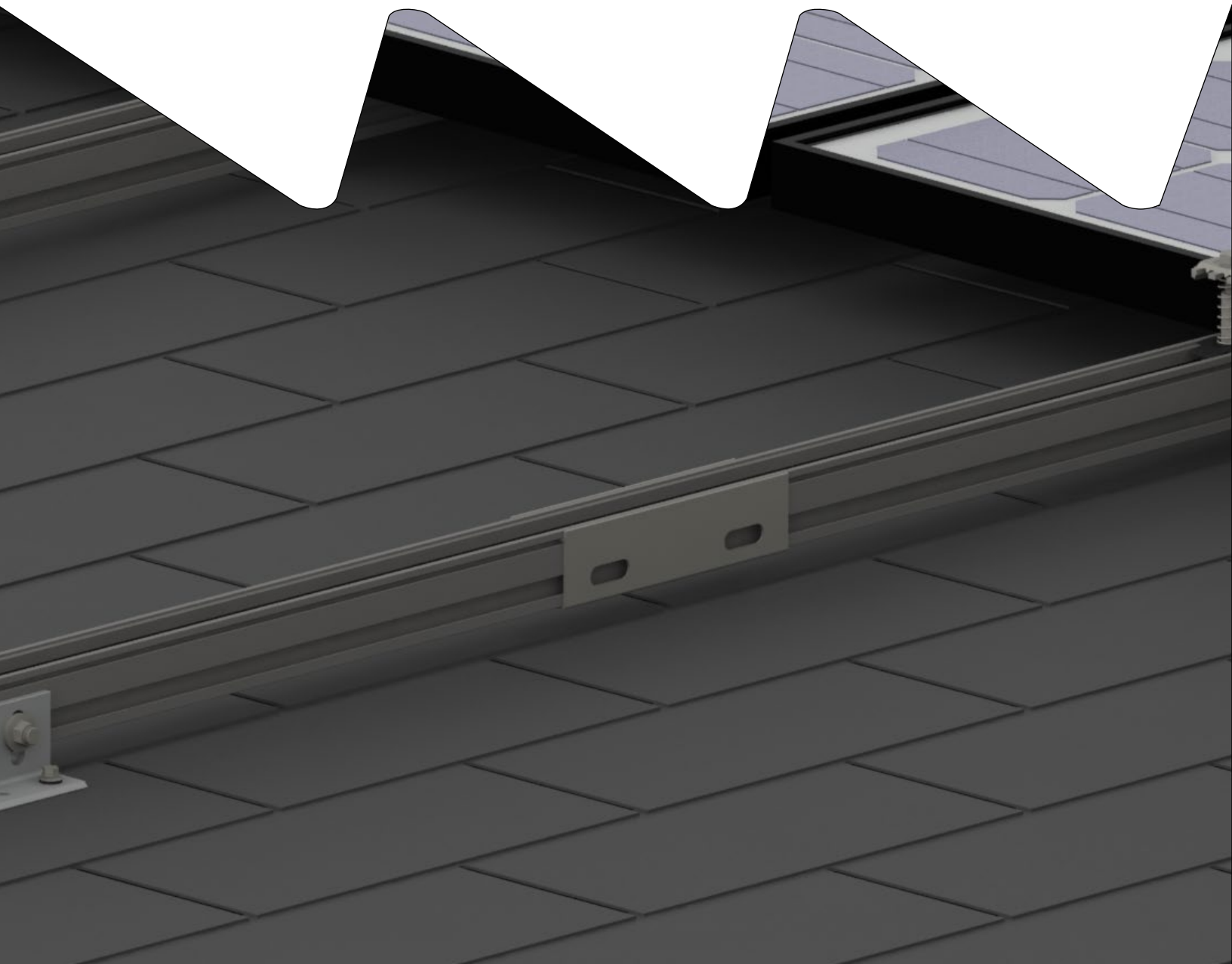

Components



1 4000051-T & 4000052-T

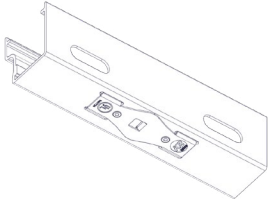

Tool-less Rail Connector, 44-X

Assembly

1

! Slide the connector onto the first rail until the end of the rail is flush against the alignment tab inside the connector.

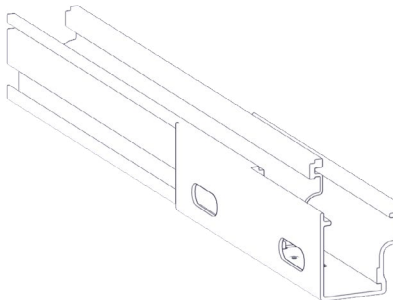
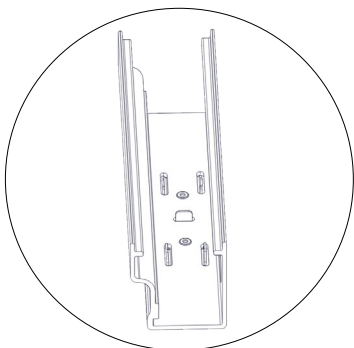

2

Slide the second rail into the connector until the end of the rail is resting flush against the alignment tab. This will ensure the Tool-Less Rail Connector is centered between both rails and the bonding teeth are in contact with the bottom of each rail. No T-bolts are needed if the rail connector is installed between roof attachments, the installation is complete.

!

Note: The product installation and uninstallation is limited to a maximum of three times.

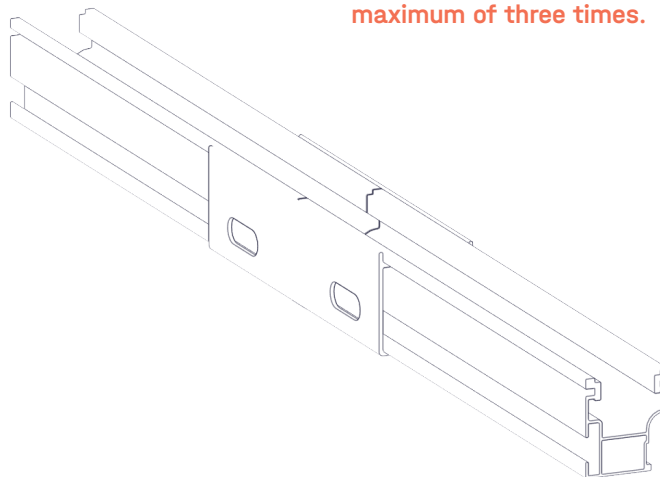

3

If using the Rail Connector to cantilever past the outer roof attachments on an array, install one T-bolt into each slot of the rail connector and into the side channel of each CrossRail (Two total). Turn the T-Bolt clockwise ensuring that the mark at the end of the shaft is vertical. Using a 13mm socket, tighten to 25.8 ft-lbs.

!

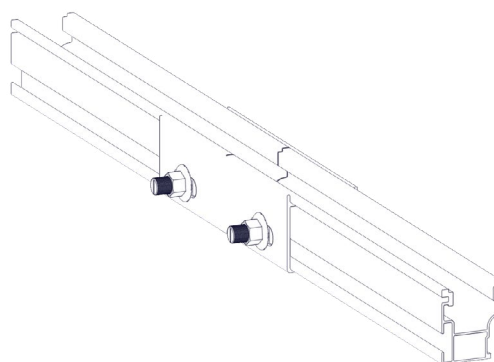
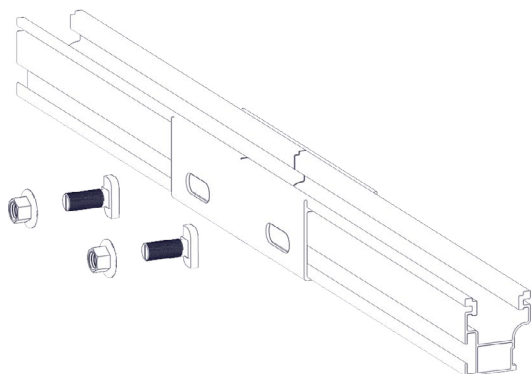



Connecting Strength

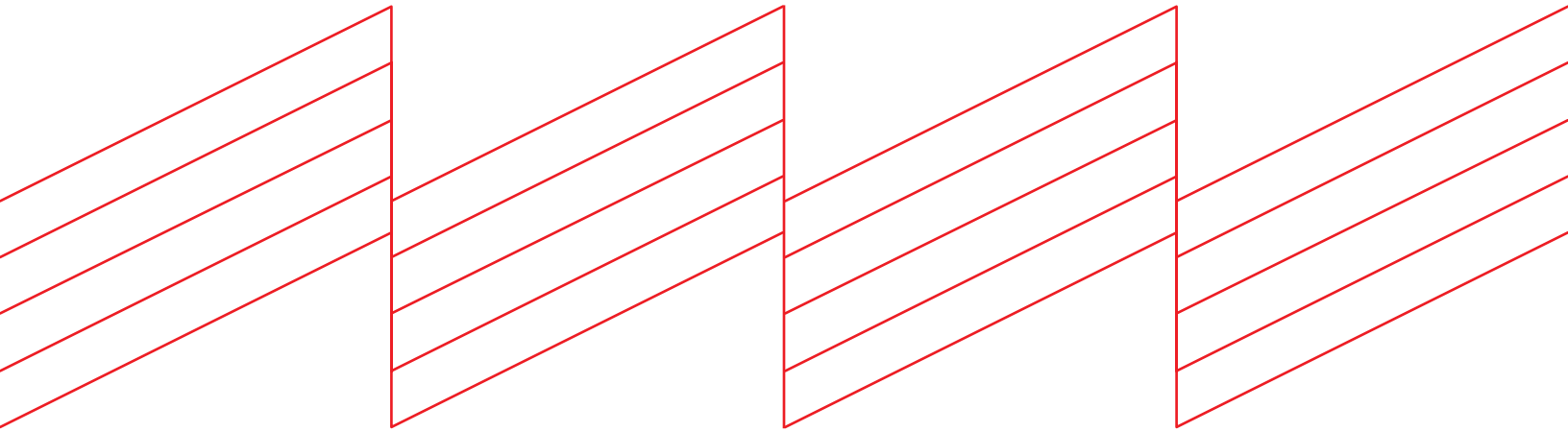

K2 Systems, LLC

4665 North Ave. Suite I • Oceanside, CA 92056 •
USA +1.760.301.5300 • infous@k2-systems.com
www.k2-systems.com/en-us

Tool-less Rail Connector Quick Guide V1 | 0624 • Subject to change •
Product illustrations are exemplary and may differ from the original.

K2 Systems

Calle Coral #2628 Interior 1 • Guadalajara, Jal. 44560
México +521 (33) 3575.9380 • info@k2-systems.mx
www.k2-systems.com/es-mx

Tool-less Rail Connector Quick Guide V1 | 0624 • Sujeto a cambios •
Las ilustraciones del producto son ejemplares y pueden diferir del original.