

# Standing Seam Rail-less

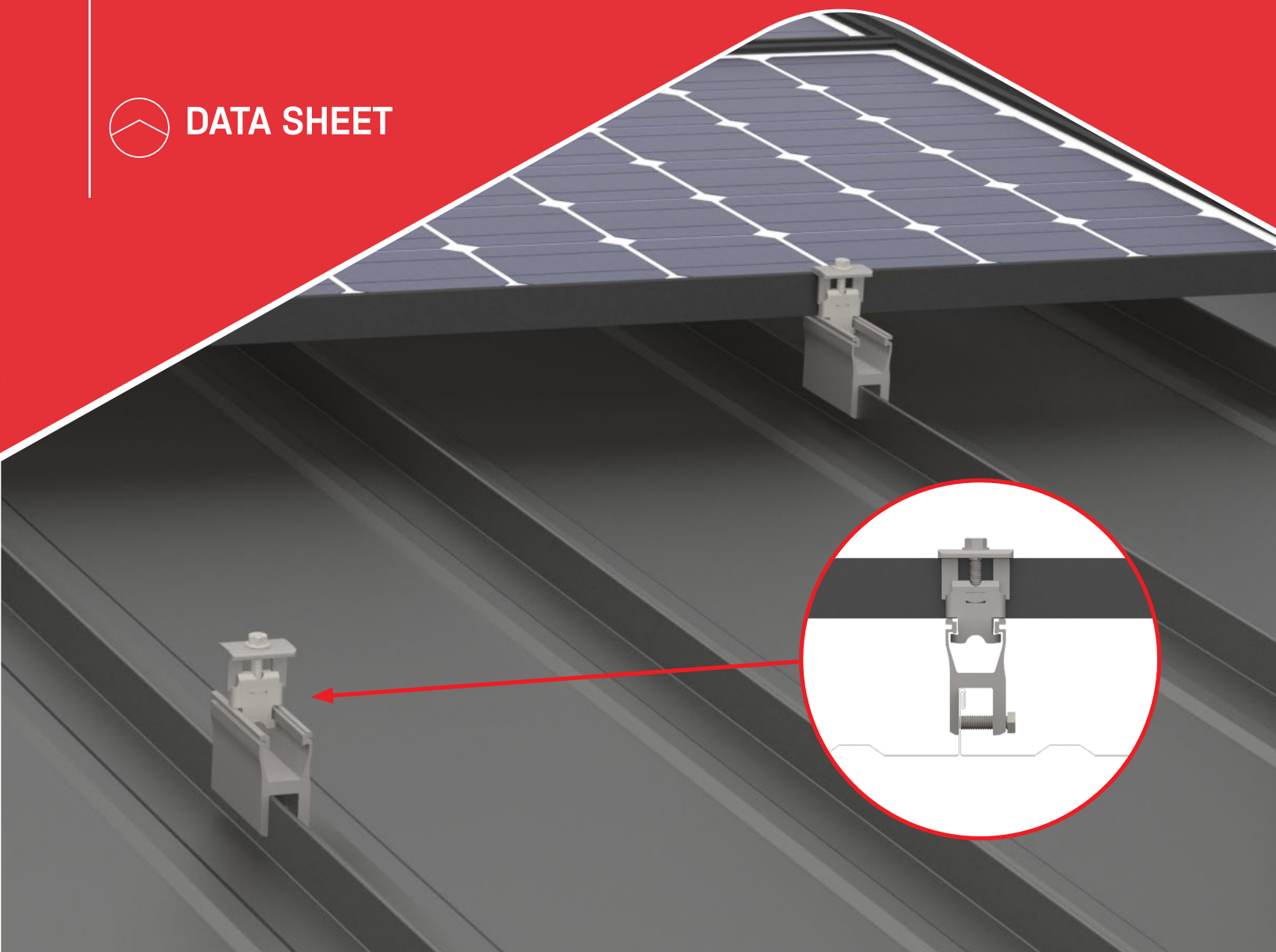

DATA SHEET



## CARACTERÍSTICAS DEL PRODUCTO

- / Solución para techos comerciales de lámina engargolada KR-18, KR24, Single y Double Lock
- / Secciones de riel 11 cm que facilitan su instalación y logística
- / La instalación rápida con cantidad mínima de componentes tan solo 3 principales, resulta un bajo costo total de instalación
- / 3cm de ajuste (N-S) para clamps, una vez instalado
- / No maltrata la lámina corrugada y sobre pasa el doble

Propiedades mecánicas	Standing Seam Rail-less
Material	6000 Series Aluminum
Terminado	Platinado
Resistencia a la tracción	34.8ksi (240Mpa)
Fuerza de rendimiento	31.2ksi (215Mpa)
Peso	0.320 kg/pieza

Unidad: [mm]

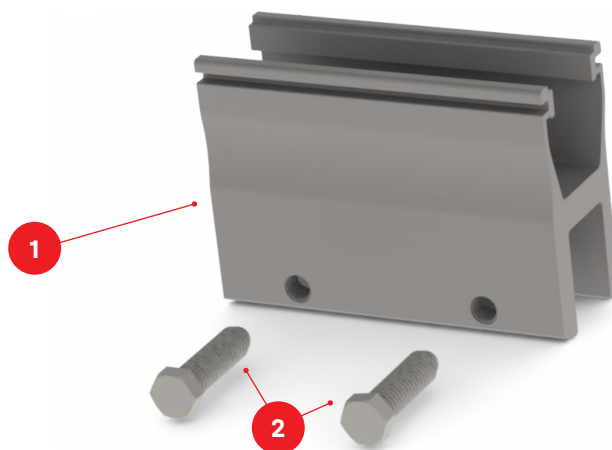
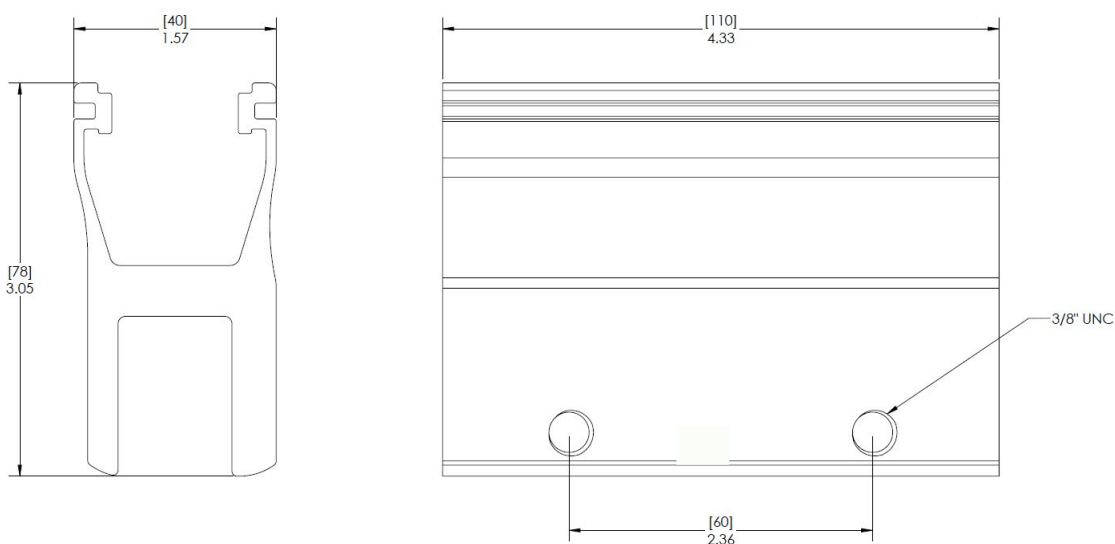

Item Number	Descripción	Part Number
1	Standing Seam Railless, Kit,Mill	4000532   Standing Seam Railless, Kit,Mill
2	Screw Oval 3-8in X 1.75in, 13mm	

# COMPONENTES DEL SISTEMA



**Standing Seam Rail-less, Kit, Mill**

Part Number	Descripción
4000532	Standing Seam Rail-less, Kit, Mill



**K2 Cross Clamp**

Part Number	Descripción
4000135	K2 Cross Clamp Set, Mill



**K2 Ground Lug**

Part Number	Descripción
4000006-H	K2 Ground Lug, 13mm Hex Set



**MLPE, Module Frame Mount, Kit**

Part Number	Descripción
4000083	MLPE, Module Frame Mount, Kit



**ILSCO Lug**

Part Number	Descripción
4000960	ILSCO, SGB-4, 4-14 SOL-STR



# Connecting Strength

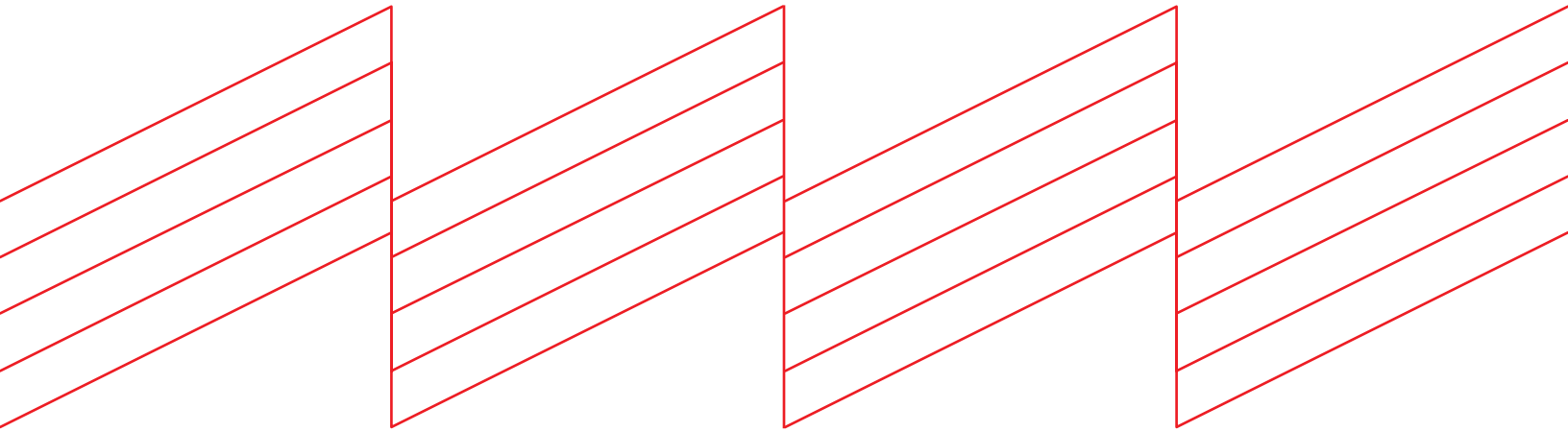

## Everest Solar Systems S de RL de CV

Calle Coral 2628 Int. 1 • Col. Residencial  
Victoria, CP 44560 • Guadalajara, Jal. • México  
+52.33.3575.9380 • info@k2-systems.mx  
www.k2-systems.com/es-mx

## K2 Systems, LLC

4665 North Ave. Suite I • Oceanside, CA 92056 •  
USA +1.760.301.5300 • infous@k2-systems.com  
www.k2-systems.com/en-us