



DEPARTMENT OF REGULATORY AND ECONOMIC RESOURCES (RER)  
BOARD AND CODE ADMINISTRATION DIVISION

**NOTICE OF ACCEPTANCE (NOA)**

MIAMI-DADE COUNTY  
PRODUCT CONTROL SECTION  
11805 SW 26 Street, Room 208  
Miami, Florida 33175-2474  
T (786) 315-2590 F (786) 315-2599  
[www.miamidade.gov/economy](http://www.miamidade.gov/economy)

**K2 Systems, LLC**  
4665 North Ave. Suite 1  
Oceanside, CA 92056

**SCOPE:**

This NOA is being issued under the applicable rules and regulations governing the use of construction materials. The documentation submitted has been reviewed and accepted by Miami-Dade County RER-Product Control Section to be used in Miami-Dade County and other areas where allowed by the Authority Having Jurisdiction (AHJ).

This NOA shall not be valid after the expiration date stated below. The Miami-Dade County Product Control Section (In Miami-Dade County) and/ or the AHJ (in areas other than Miami-Dade County) reserve the right to have this product or material tested for quality assurance purposes. If this product or material fails to perform in the accepted manner, the manufacturer will incur the expense of such testing and the AHJ may immediately revoke, modify, or suspend the use of such product or material within their jurisdiction. RER reserves the right to revoke this acceptance if it is determined by Miami-Dade County Product Control Section that this product or material fails to meet the requirements of the applicable building code.

This product is approved as described herein and has been designed to comply with the Florida Building Code, including the High Velocity Hurricane Zone.

**DESCRIPTION: K2 Aluminum Multi Mount**

**APPROVAL DOCUMENT:** Drawing titled "Multi Mount Assembly", sheets 1 through 2 of 2, prepared by K2 Systems, dated 10/28/2024, signed and sealed by Russell N. Emery, P.E., bearing the Miami-Dade County Product Control approval stamp with the Notice of Acceptance number and expiration date by the Miami-Dade County Product Control Section.

**MISSILE IMPACT RATING: None**

**LABELING:** Each box shall bear a permanent label with the manufacturer's name or logo, city, state and following statement: "Miami-Dade County Product Control Approved or MDCPCA", unless otherwise noted herein.

**RENEWAL** of this NOA shall be considered after a renewal application has been filed and there has been no change in the applicable building code negatively affecting the performance of this product.

**TERMINATION** of this NOA will occur after the expiration date or if there has been a revision or change in the materials, use, and/or manufacture of the product or process. Misuse of this NOA as an endorsement of any product, for sales, advertising or any other purposes shall automatically terminate this NOA. Failure to comply with any section of this NOA shall be cause for termination and removal of NOA.

**ADVERTISEMENT:** The NOA number preceded by the words Miami-Dade County, Florida, and followed by the expiration date may be displayed in advertising literature. If any portion of the NOA is displayed, then it shall be done in its entirety.

**INSPECTION:** A copy of this entire NOA shall be provided to the user by the manufacturer or its distributors and shall be available for inspection at the job site at the request of the Building Official.

This NOA consists of this page 1, evidence page E-1, as well as approval document mentioned above.

The submitted documentation was reviewed by **Carlos M. Utrera, P.E.**

01/23/25



NOA No: 24-0805.05  
Expiration Date: January 30, 2030  
Approval Date: January 30, 2025

**NOTICE OF ACCEPTANCE: EVIDENCE SUBMITTED**

**A. DRAWINGS**

1. Drawing titled “Multi Mount Assembly”, sheets 1 through 2 of 2, prepared by K2 Systems, dated 10/28/2024, signed and sealed by Russell N. Emery, P.E.

**B. TESTS**

1. None.

**C. CALCULATIONS**

1. Engineering report prepared by Vector Engineers, dated 10/28/2024, signed and sealed by Russell N. Emery, P.E.

**D. MATERIAL CERTIFICATIONS**

1. None.

**E. QUALITY ASSURANCE**

1. Miami-Dade Department of Regulatory and Economic Resources (RER).

**F. STATEMENTS**

1. Statement letter of code conformance to the 8<sup>th</sup> edition (2023) of the FBC, issued by Vector Engineers, dated 10/28/2024, signed and sealed by Russell N. Emery, P.E.
2. Statement letter of no financial interest issued by Vector Engineers, dated 08/26/2024, signed and sealed by Russell N. Emery, P.E.



---

**Carlos M. Utrera, P.E.**  
**Product Control Examiner**  
**NOA No: 24-0805.05**  
**Expiration Date: January 30, 2030**  
**Approval Date: January 30, 2025**

EPDM Washer must be pushed all the way to the top, just under the screw head during the assembly. The gap between the washer and the head of the screw shouldn't exceed 5mm. The metal surface of the washer should face the head of the screw and the EPDM at the tip.

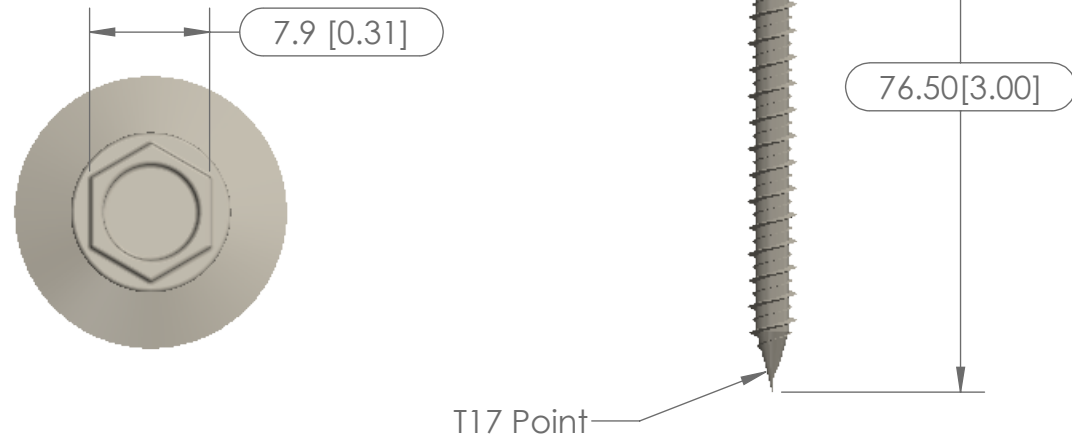

ITEM NO.	PART NUMBER	DESCRIPTION	QTY.	Alloy
1	4000283	K2 Multi Mount, Dark	1	6061-T6, 6005A-T5, 6005A-T61
2	4000281	Multi Mount Butyl	1	N/A
3	4000310	#14 x 3in x 0.3125in Hex Head Screw	3	18-8 stainless Steel
4	4000310	#14 x 3in x 0.3125in Hex Head Screw washer	3	N/A
5	400360	Lag Screw D14 5/16 x 4"	1	18-8 stainless Steel
6	400360	EPDM Washer	1	N/A

MULTI MOUNT FOR TILE ROOF MOUNTING (IN RAFTER)

2 Types of configurations:

- ▷ (3) #14 x 3in x 0.3125in Hex Head Screw, EMBED FULLY INTO RAFTER
- ▷ (1) 4000360 - K2 Lag Screw 5-16in x 4in, Hex Head 13mm - EMBED FULLY INTO RAFTER

MINIMUM DECK = 15/32"

REFER TO K2 ENGINEERING CHARTS FOR APPLICABLE CROSSRAIL SPANS

REFER TO K2 MULTI MOUNT ENGINEERING LETTER FOR ADDITIONAL INFORMATION

- ▷ NO PILOT HOLE REQUIRED FOR SELF DRILLING SCREWS
- ▷ REFER TO K2 CROSSRAIL INSTALATION MANUAL FOR HARWARE TORQUE

STRUCTURAL MEMBER SPECIFICATIONS:

- MINIMUM WOOD GRADE = SPF #2
- SPECIFIC GRAVITY= 0.42
- MINIMUM FASTENER EDGE DISTANCE = 0.375"
- MINIMUM FASTENER END DISTANCE = 1.4

	3 Screws	1 lag screw
ALLOWABLE FASTENER	RAFTER	RAFTER
UPLIFT	1020 lbs	758 lbs
LATERAL	300 lbs	261 lbs

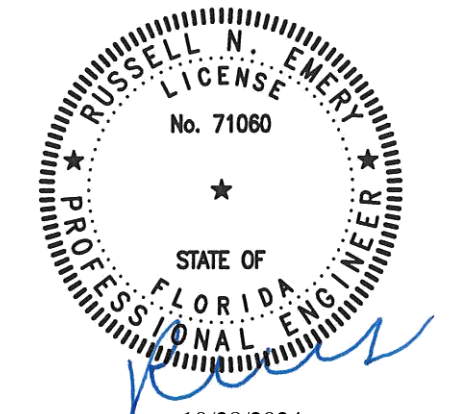
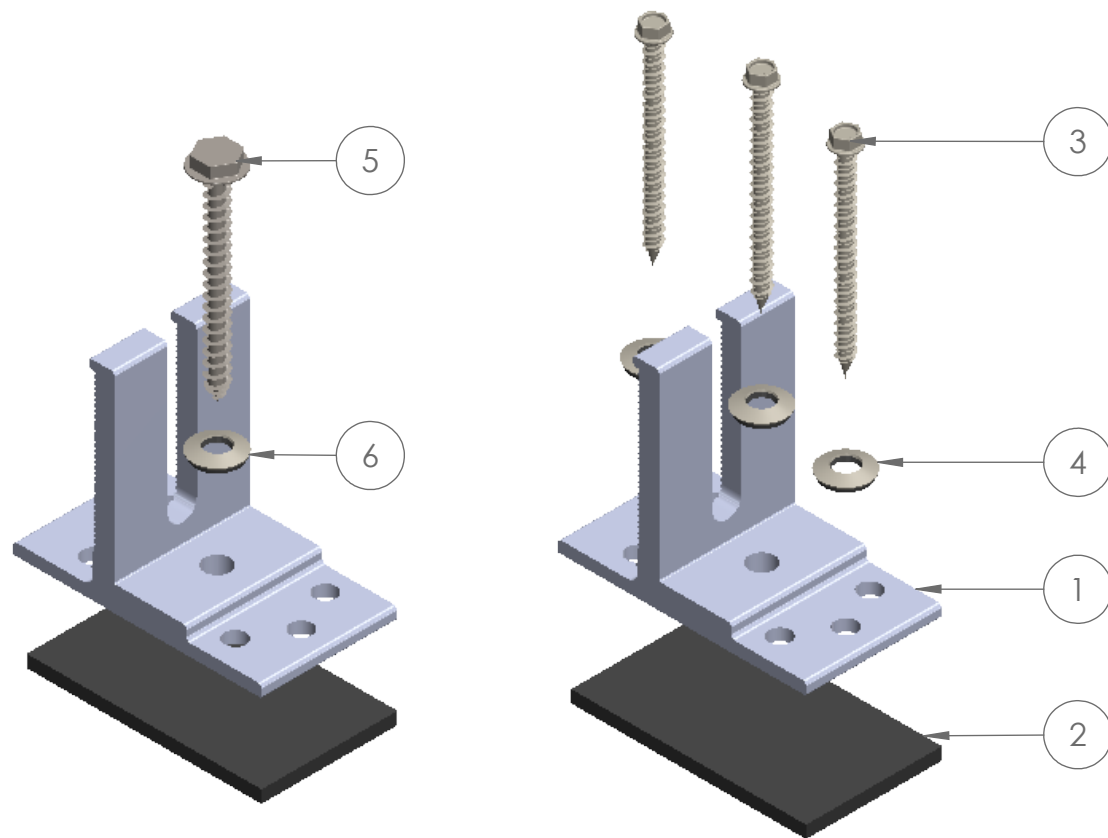

**PRODUCT APPROVED**  
 as complying with the Florida Building Code  
 NOA-No. 24-0805.05  
 Approval Date 01/30/2025  
 By *[Signature]*  
 Miami-Dade Product Control

10/28/2024  
 Russell N. Emery  
 No. 71060  
 VSE Project Number: U6022.0009.241

REVISION	DATE	DESCRIPTION	DRAWN BY
A	1/30/24		A. VIZCARRA

Sheet: 1 OF 2

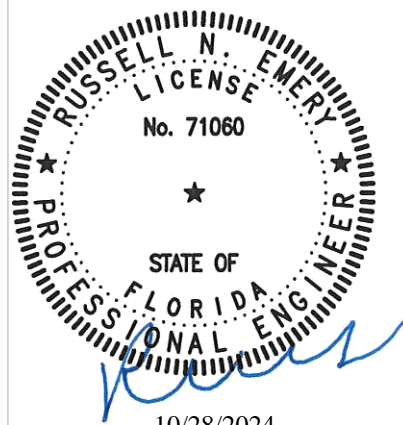
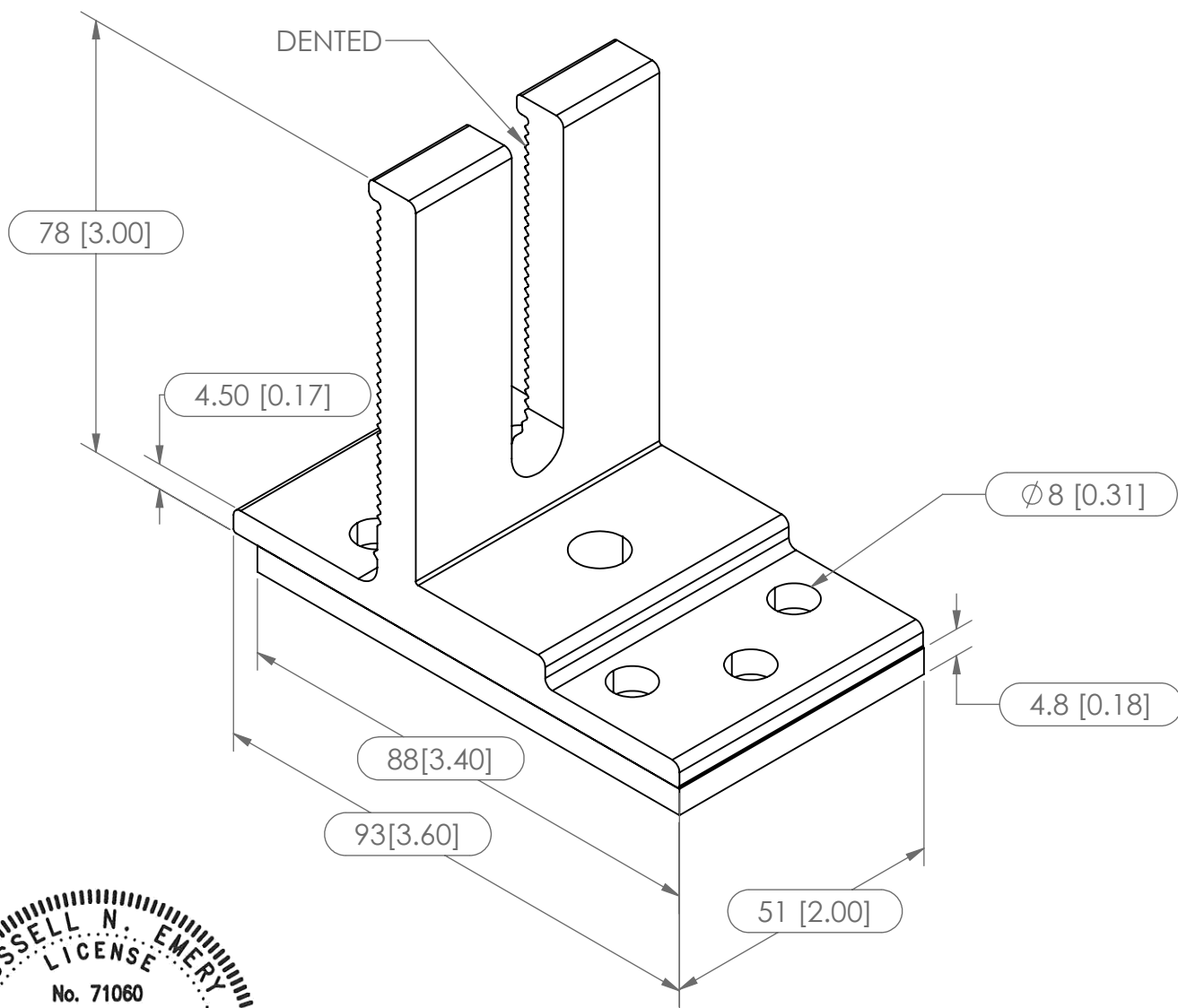

10/28/2024  
 Russell N. Emery  
 No. 71060



651 W. GALENA PARK BLVD. STE. 101 PHONE (801) 990-1775  
 DRAPER, UTAH 84020 WWW.VECTORSE.COM

VSE Project Number: U6022.0009.241

- 1 Locate the rafter and clean roofing surface for mount placement. Peel back protective paper from butyl and stick down mount on a single shingle course with the center hole lining up over the rafter. Position all mounts in the same direction with the long side towards the ridge. Drive chosen lag screws into the rafter until the conical washer stops rotating, providing a positive seal. Do not over-torque. It should be tightened until the conical washer stops rotating. For rafter attach there are three different configurations to ensure a proper installation of the mount.

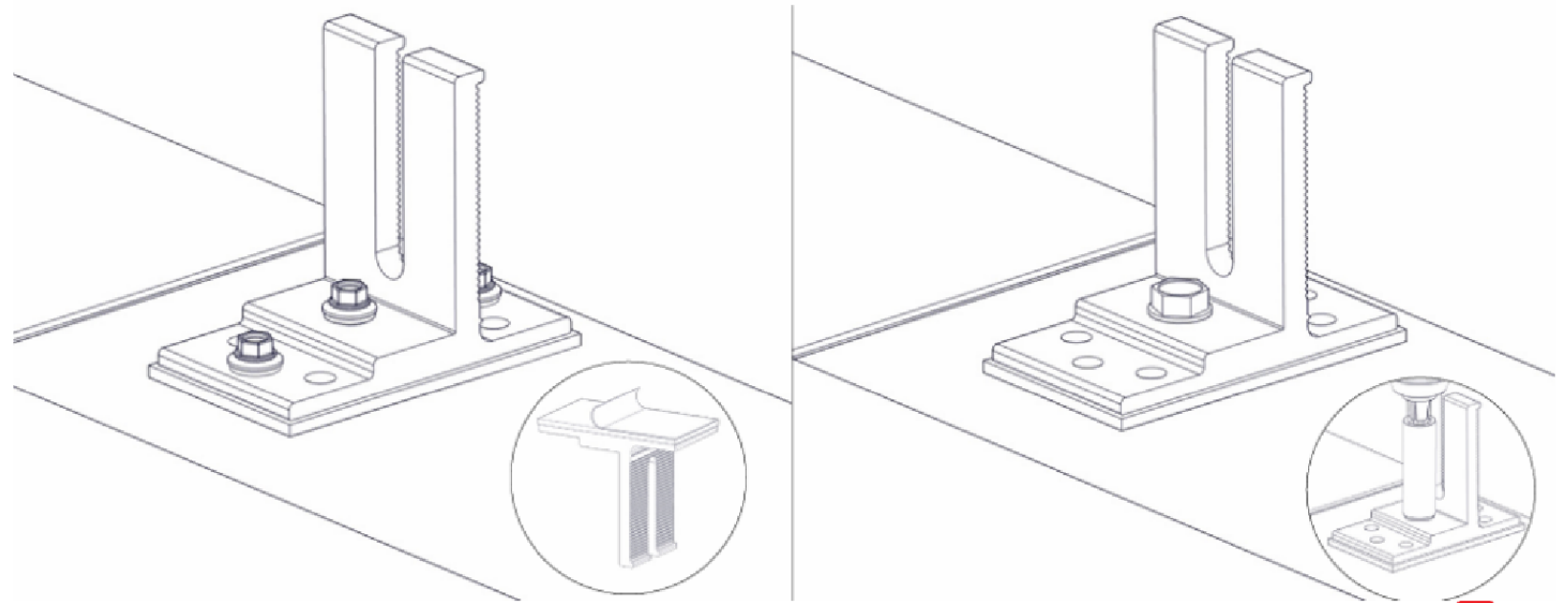

- ! The distance from the edge of the rafter and the wood screws must be at least 5/16" from the edge.

**PRODUCT APPROVED**  
 as complying with the Florida  
 Building Code  
 NOA-No. 24-0805.05  
 Approval Date 01/30/2025  
 By *[Signature]*  
 Miami-Dade Product Control



**Note: Minimum Edge Distance = 1.5D Where D is the diameter of the screw.**

**Note: The screw should hit the area that is marked by the red box**

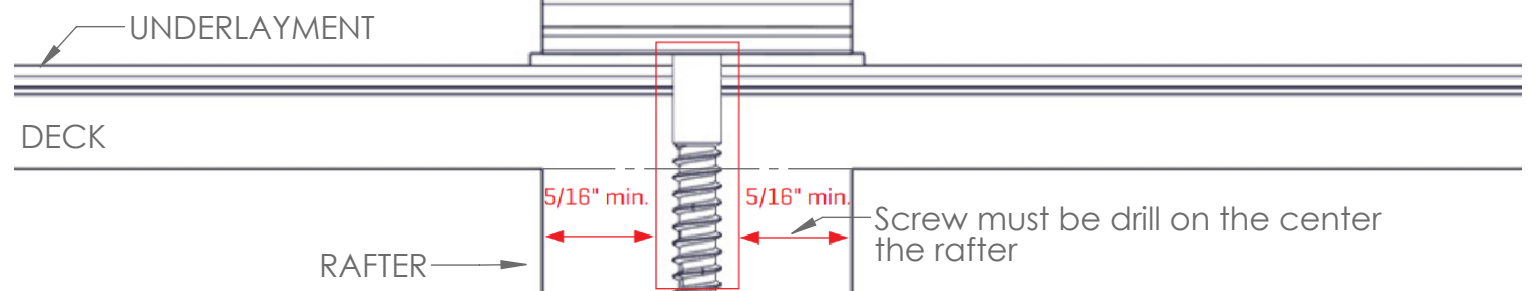

K2 Systems  
 3809 Ocean Ranch Blvd. Suite 111  
 Oceanside, CA 92056  
 phone 760.301.5300

Description:  
 MULTI MOUNT ASSEMBLY

REVISION	DATE	DESCRIPTION	DRAWN BY
A	1/30/24		A. VIZCARRA
		SHEET 2 OF 2	

Project:  
 Miami Dade County NOA